

Mounded Wastewater Treatment Systems

A Technical Guidance for Site Suitability, Design, Construction, Operation and Maintenance

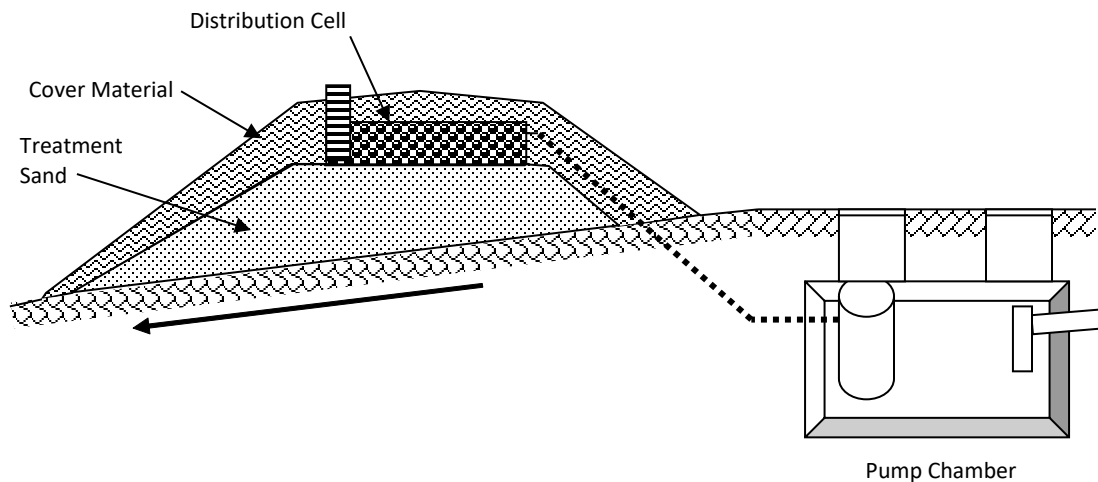

Colorado Department of Public Health and
Environment; Water Quality Division;
Onsite Wastewater Treatment System Program

Original Publication: June, 2017

Revised: August, 2017; August, 2020

PREFACE

The technical guidance contained in this document has been developed to assist with the statewide application of section 43.11.D of Regulation 43, "On-site Wastewater Treatment System Regulation", Effective, June 30, 2017. This guidance document provides procedures for the design of a mounded on-site wastewater treatment system. Section 43.11.D of Regulation 43 defines the actual minimum standards required for the installation of a mounded wastewater treatment system in Colorado. Therefore, if there is confusion or conflict in the suggested design process stated within this document and the requirements found in section 43.11.D of Regulation 43, the requirements of Regulation 43 must be used.

This document describes two separate design procedures:

- The design of a mound system with ≥ 24 inches of sand below the distribution media.
- The design of a mound system with < 24 inches of sand below the distribution media.

The differences in these two designs are noted at various locations throughout this document, including the two separate design examples provided in Appendix B-1 and Appendix B-2.

NOTE: August 2020 edits were conducted to clarify vertical separation requirements within Regulation 43. That is, the requirements of Sections 43.11.C.3.a - e must be followed; as noted in Section 43.11.D.3 of Regulation 43. Additional clarification was added to the calculations to identify how far downslope the imported treatment sand must be installed. This was separated from the "toe of slope" requirements that typically relate to the soils, percent of slope, and height of the mound.

Reference: Concepts and requirements provided in this document were obtained from, section 43.11.D of Regulation 43, the *Wisconsin Mound Soil Absorption System: Siting, Design, and Construction Manual, January 2000*; and the *Michigan Department of Environmental Quality Water Division, Land Division and Local Health Department Support Program, June 2003*.

TABLE OF CONTENTS

Definitions	4
Introduction	6
Site Evaluation and Planning	7
System Design Procedure.....	8
Site Preparation and Construction	10
Operation and Maintenance	11
Owner’s Manual	12
Appendix A - List of Figures and Tables	12
Figure 1- Mound System Components	13
Figure 2 - Typical Site Plan	14
Figure 3 - Mound Dimension Reference and Cross Section	15
Figure 4 - Treatment Sand Specifications	16
Table 1 - Allowable Loading Rates (≥ 24 Inches of Sand).....	17
Table 2 - Allowable Loading Rates (< 24 Inches of Sand)	18
Table 3 - Slope Correction Factors	19
Appendix B-1 - Design Example (For Sites with ≥ 24 Inches of Sand).....	20
Appendix B-2 - Design Example (For Sites with < 24 Inches of Sand).....	26
Appendix C - Mound Design Worksheet.....	28
Mound System Dimensions	35
Appendix D - Plan Submittal Checklist	36
Appendix E - Mound Maintenance Checklist	38
Appendix F - Vertical Separation Guidance.....	40

DEFINITIONS

Basal Area: The effective surface area available to transmit the treated effluent from the filter media in a mound system into the in-situ receiving soils. The perimeter is measured at the interface of the imported fill material and in-situ soil. On sloping sites, only the area down-gradient from the up-slope edge of the distribution media may be included in this calculation.

Cover Material: The material used to cover a mound system, usually selected on its ability to support vegetation, transfer oxygen, and shed water. A soil type 1 or soil type 2 with a thin topsoil cover adequate to assist in the growth of the selected vegetation is preferred.

Distribution Cell Area: The area within the mound where the effluent is dispersed through a system of small diameter pipe that has been installed within a distribution media (i.e.: gravel, chambers, etc.)

Greenbelt Area: The area measured horizontally downslope from the edge (toe) of the mound fill, which is maintained undisturbed prior to, during, and after construction so as not to impede lateral movement of effluent through the soil.

High Groundwater Elevation: The uppermost part of the soil or underlying material which shows indications of saturation, or a perched or apparent water table condition, that may be seasonally saturated or show indications of redoximorphic features.

Hydraulic Linear Loading Rate: The volume of effluent applied per day per linear foot along the natural ground contour (gpd/linear ft).

Infiltrative surface: means designated interface where effluent moves from distribution media or a distribution product into treatment media or original soil. In standard trench or bed systems this will be the interface of the distribution media or product and in-situ soil. Two separate infiltrative surfaces will exist in a mound system and an unlined sand filter, one at the interface of the distribution media and fill sand, the other at the interface of the fill sand and in-situ soil.

In Situ Soil: Soil present in the natural or original position; undisturbed soil.

Limiting Layer: A horizon or condition in the soil profile or underlying strata that limits the treatment capability of the soil or severely restricts the movement of fluids. This may include soils with low or high permeability, impervious or fractured bedrock, or a seasonal or current ground water surface.

Mound: A soil treatment area whereby the infiltrative surface is at or above original grade at any point.

Original Grade: The natural land elevation which exists prior to the construction of the mound system.

Pressure Distribution: A uniform application of wastewater throughout the intended portion of the soil treatment area through small diameter pipes and orifices, under pressure. For this definition, the term pressure indicates that the system is capable of creating upward movement of effluent out of the distribution system piping.

Redoximorphic Features (also known as “Soil Mottling”): A soil property that results from the reduction and oxidation of iron and manganese compounds in the soil after saturation with water and subsequent de-saturation.

Soil Compaction: An increase in the soil bulk density and decrease in soil porosity by the application of mechanical forces to the soil that results in a soil that retains less water and resists root penetration. Soils with high clay content are more easily compacted than sandy soils.

Soil Loading Rate (Basal Area Loading Rate): The allowable application rate to the basal area required for absorption of effluent based upon soil texture for a given soil structure.

Suitable Soil: A soil which will effectively treat and filter effluent by removal of organisms and suspended solids, which meets long-term acceptance rate requirements as defined in Table 10-1 of Regulation 43, and has the required vertical thickness below the infiltrative surface and above a limiting layer.

Treatment Sand: Sand meeting a specific criteria regarding particle size and uniformity to ensure an expected treatment of the wastewater as defined in section 43.11.C.2.d of Regulation 43. Also noted in Figure 4 of this document.

Vertical Separation: The total depth of suitable soil or appropriate fill that is required between the infiltrative surface and a limiting layer. A copy of the Division’s “Vertical Separation” clarification document has been provided in Appendix F

INTRODUCTION

When properly sited, designed, constructed, operated and maintained, mound systems provide a proven effective alternative method of on-site treatment. A mound system relying on subsurface distribution to in situ soils can be an effective solution where existing site conditions are not suitable for conventional treatment and dispersal systems. Typical situations where mound systems might be applied include:

- **Permeable or slowly permeable soils with a high groundwater elevation.**

Where permeable or slowly permeable soils with a high groundwater elevation prevent the installation of a conventional treatment system, a mound may be an acceptable alternative to provide for final treatment and dispersal. Utilizing a mound system with pressure distribution of effluent to promote unsaturated flow along with elevating the infiltrative surface to provide the necessary vertical separation maximizes treatment of the effluent.

- **Slowly permeable soils without high groundwater.**

Slowly permeable soils are most effective for final treatment where the natural soil profile is maintained in minimally disturbed condition. Utilizing a mound system with pressure distribution for these sites offers a number of advantages as opposed to attempts to construct a conventional below grade final treatment and dispersal system including:

- Damage to the natural soils during construction including compaction and smearing is minimized.
- Treated effluent is discharged and dispersed into the uppermost soil horizons, which are typically more permeable and will provide additional treatment.
- The imported treatment sand provides initial treatment of the effluent, which minimizes clogging of the slowly permeable soils while maintaining their hydraulic conductivity.
- Utilizing pressure distribution promotes unsaturated flow resulting in more efficient treatment, extended life of the system and improves overall hydraulic performance by minimizing groundwater mounding.

- **Excessively permeable soils or creviced bedrock.**

Excessively permeable natural soils or shallow soils over creviced bedrock present distinct concerns related to contamination of groundwater supplies or surface waters. In conjunction with a comprehensive evaluation of site specific environmental and/or public health concerns, mounds may assist in the treatment of the effluent to minimize adverse impacts to groundwater.

SITE EVALUATION AND PLANNING

A critical step in the successful application of mound technology is the site evaluation and planning process. This step provides the site specific information necessary to evaluate overall site suitability and is used as the foundation for actual design.

Prior to completing the site evaluation, available site specific information related to soils, slopes, etc., should be reviewed in detail. The U.S. Department of Agriculture (USDA) soil survey may be an additional valuable resource in this regard. This information will provide general guidance as to the potential for the site relative to the use of mound technology. After a thorough review of this information, preliminary site plans can be developed and a site evaluation conducted.

This web site can be accessed at:

<https://websoilsurvey.sc.egov.usda.gov/App/HomePage.htm>

For each site where a mound is intended, a minimum of two soil profile test pit excavations are required to delineate the proposed soil treatment and greenbelt areas and to establish consistency of the soils. Percolation tests may also be conducted if additional information regarding site permeability is needed. Soil evaluations should be completed during those time periods where soils are sufficiently dry, and if possible conducted directly adjacent to the basal area (off to the side of the proposed distribution bed if possible) to avoid damage to any portion of the absorption area. Soil evaluations must be completed by observation of shallow soil pits of adequate size, depth, and construction to safely enter and exit the pit and complete a soil profile description. All of the following must be accurately reported by a competent soil technician:

- Thickness of each soil strata
- USDA soil textural class
- Presence of soil mottles or redoximorphic features
- Soil structure - grade and type
- Occurrence of saturated soil, groundwater, bedrock, or disturbed soils

Requirements noted in the "Report and Site Plan" as defined in section 43.5.F of Regulation 43 must be submitted.

Site planning for mound system installations must also consider the following features:

- Property lines
- Slope
- Required setback distances
- Existing or proposed structures
- Existing or proposed wells
- Surface waters
- Location of the soil profile test pit excavations

SYSTEM DESIGN PROCEDURE

Sufficient detail must be provided for the design and installation of an on-site wastewater treatment system as defined in section 43.5.G of Regulation 43. The location for the proposed mound system must be readily accessible for construction and for future maintenance and repair. A proper design must allow for the construction of proposed buildings and any other site improvements, while maintaining all required setbacks. The approved plan must indicate the location of a suitable benchmark to be used by the contractor during construction. The following terms define the necessary specifications for the design of a mounded wastewater treatment system:

Depth of Treatment Sand - Various sand fill depths are allowed to obtain the minimum vertical isolation requirements of Regulation 43 (Vertical Isolation Chart provided in Appendix "F"), depending on the quality of effluent applied to the mound system. Note that in order to obtain TL3 effluent as provided in Regulation 43, a minimum of 24 inches of imported treatment sand is required below the distribution cell.

Design Flows - Wastewater flows as defined within section 43.6 of Regulation 43 must be followed. This should provide an adequate factor of safety necessary to promote satisfactory long term function of the mound system. Where exact water meter readings have been obtained for commercial or industrial sites, the design flows should be multiplied by 1.5 to 2 times the meter reading to provide the necessary factor of safety.

Distribution Cell Sizing - The distribution cell must be sized per the equations provided in the Mound Design Worksheet (Appendix C of this document). The design flow, sand fill loading rate and linear loading rate will determine the length and width of the distribution cell. The maximum allowable width is 12 feet, unless TL2 thru TL3N effluent is applied to the distribution media above a soil type 1 thru 3.

Final Cover - The settled depth of final cover at the outer edge of the distribution cell must be a minimum of 10 inches, and at the top of the mound provide a greater depth to promote positive drainage. Final cover over the mound should support the growth of a suitable vegetative cover while shedding rainfall and promoting aeration of the mound. The final cover over a mound system must extend at least twelve inches horizontally beyond the edge of the distribution media prior to sloping down to existing grade. Final cover must have a texture no heavier than sandy loam with a topsoil cap. The final side slope of the mound surface should be 3:1 or flatter.

Hydraulic Linear Loading Rate - The hydraulic linear loading rate is the volume of effluent applied per day per linear foot of system along the natural ground contour. From a hydraulic standpoint, a long and narrow mound design is most efficient and better promotes aerobic conditions under the distribution cell. Linear loading rates are provided in section 43.11.D.5.a, b, and c of Regulation 43, and Tables 1 and 2 of this document.

Mound Orientation - On a sloping site, the absorptive area must be installed long and narrow with the long dimension running parallel to the contour. This orientation minimizes the hydraulic linear loading rate to the in-situ soils.

Pressure Distribution System - Pressure distribution of effluent is required in the distribution cell to promote unsaturated flow and the maximum achievable treatment through the sand media. The pressure distribution system design must comply with the criteria established in section 43.10.E.3, and section 43.11.C.3.a thru e of Reg. 43.

Sand Media Loading Rate - This relates to a defined permeability of the imported sand media. The specifications for allowable sand media are defined in section 43.11.C.2.d of Regulation 43 and Figure 4 of this document. Two types of sand media are accepted; "Preferred" sand media will have a loading rate of 1.0 gpd/ft². "Secondary" sand media will have a loading rate of 0.8 gpd/ft².

Setbacks - Table 7-1 of Regulation 43 defines the minimum setbacks that must be maintained from specific water, physical and health impact features.

Site Slopes - Site slope restrictions are primarily for construction safety concerns. Systems on steep slopes with slowly permeable soils must be long and narrow to reduce hydraulic overload and the possibility of leakage out the toe of the mound. A 25% slope limit is recommended which is based on construction and grading concerns, and not soil or hydraulic limitations.

Sites with Boulders and Trees - Care should be taken during construction whenever boulders and trees are encountered. It is best not to remove these items as the process may compact or disturb the soil structure within the proposed treatment area. Trees should be cut at grade and the stumps left in place. Should either occupy a significant amount of surface area, the size of the mound should be increased to adjust for the reduced area.

Slope Segment Position - The distribution system should be placed near the crest of the slope; or provide for diversion of upslope surface water and groundwater. The absorptive area should be placed long and narrow on a convex slope. Concave slopes should be avoided as they will concentrate groundwater toward both the basal area and the greenbelt.

Soil Loading Rate - The minimum mound basal area required for absorption of effluent is based upon soil texture, structure and the slope of the site. The maximum soil loading rates are based upon the soil texture and structure encountered. The allowable rates are defined in Table 1 and 2 of this document. Soil types are defined in Table 10-1 or 10-1A of Regulation 43. The basal area for sloping sites (i.e., those with slopes ≥ 2 percent) includes the area under the distribution cell and the area downslope only. On flat sites (i.e., those with slopes ≤ 2 percent), the minimum required basal area includes the area under the distribution cell and on all sides of it. Generally, the minimum required basal area will be found to be less than the actual area filled after accounting for required depth of fill and side slopes.

Waste Strength - Design criteria within this document assumes that the mound system is designed to accept domestic septic tank effluent (TL1). As per the requirements of Regulation 43, higher strength effluent must be treated to this standard prior to application to a soil treatment area.

SITE PREPARATION AND CONSTRUCTION

Ultimate success or failure of a mound relies on a clear communication between the regulator, design engineer, and the system installer, which includes an understanding of basic site preparation and construction principles. Critical issues are noted below:

- Proper procedures must be followed to protect the entire mound area, including the down-gradient greenbelt area, both during and after construction. After establishing a suitable location for the mound system, it should be suitably fenced or otherwise unmistakably identified to prevent further disturbance until actual construction of the mound system can occur. Site planning resulting in a location for the mound that is isolated from other anticipated home construction activities is encouraged.
- Soil smearing and compaction, which can reduce infiltration capacity, will occur if soils are disturbed when wet. Mound system construction activities should be scheduled only when soils are sufficiently dry. Acceptable soil moisture content of the soils to a depth of one foot should be evaluated by rolling a sample of soil between the hands. If the soil can be rolled into a 1/4 inch or smaller "wire" it is considered too wet and must be allowed to dry before preparing.
- Excess vegetation must be removed from the mound basal area. Trees should be cut flush to the ground and other vegetation over six inches in length should be mowed and subsequently removed.
- The ground surface of the entire basal area of the mound should be suitably prepared by roughening in a ridge and furrow fashion with ridges following the contours. Methods that can be considered for roughening include chisel teeth fastened to the backhoe bucket, plowing with a multiple bottom agricultural chisel plow, or moldboard plow. Rototilling is not acceptable as it will destroy soil structure. Sand fill material should be applied immediately after roughening and prior to any subsequent precipitation. (PROPER SITE PREPARATION IS CRITICAL TO THE FUNCTION OF A MOUND AND SHOULD NOT BE OVERLOOKED)
- A gradation of the treatment sand must be provided prior to installation to ensure the proper sand fill loading rate. Placement of the treatment sand must then be accomplished from the end and upslope sides utilizing a tracked vehicle or equipment with adequate reach to minimize soil compaction. A minimum of eight inches of fill material should be maintained below the tracks to minimize compaction. Wheeled vehicles must be prevented from travel over the mound basal area and downslope greenbelt area. The top of sand shall extend 12" beyond the edge of the distribution cell on all sides.

- Final grading of the mound area should divert surface water drainage away from the mound. The entire mound area should be seeded and mulched to promote vegetative growth. The suggested minimum greenbelt area is provided in Table 1. This dimension is based on soil texture and the slope of the site.

OPERATION AND MAINTENANCE

The owner is responsible for ensuring the continuous operation and maintenance of the system. It is recommended that deed advisories be recorded to communicate to the system owner and subsequent future owners the importance of routine and regular maintenance activities. It is suggested that a maintenance inspection be conducted on an annual basis by a trained maintenance provider. The local public health agency or other management entity may require oversight of the on-site system by a maintenance provider. In such cases, the maintenance provider will be responsible for the continuous operation and maintenance of the system and must submit appropriate inspection records to the local agency or other appropriate jurisdiction.

Suggested routine and preventative maintenance will include:

- Scum and sludge levels in the septic tank as well as the pump chamber need to be routinely inspected and tanks pumped as necessary. Depending on tank size and usage, pumping will typically be required at intervals exceeding every 3 to 5 years.
- A periodic inspection of the mound system's performance is necessary to ensure proper and continued function. Liquid levels in the observation ports should be checked and examinations made for any seepage around the extents of the mound. The pressure distribution system should be assessed and laterals flushed as necessary. It is recommended that all components of a mound system be evaluated and maintained at least once per year. A suggested maintenance visit checklist is attached (Appendix E).
- A water conservation plan within the house or establishment will help ensure that the mound system will not be hydraulically overloaded.
- Avoid traffic above the mound and downslope greenbelt area. No vehicular traffic or livestock should be permitted. With lawn care equipment, such as a riding lawn mower or tractor, it is important not to travel on the mound or the downslope area when the soil is saturated. Winter traffic on the mound should also be avoided to minimize frost penetration in colder climate areas and to minimize compaction in other areas.

Owner's Manual

An owner's manual needs to supplement the construction plan and must be submitted to the local public health agency for final approval. A copy of this manual must be provided to the property owner after completion of the mound system. The manual needs to contain the following as a minimum:

1. As-built drawings of all system components and their location are to be provided.
2. Specifications for all electrical and mechanical components.
3. Names and phone numbers of local public health authority, component manufacturer, or management entity to be contacted in the event of an alarm, or other problems, or failure.
4. Information on the periodic maintenance of the mound system, including electrical/mechanical components.
5. Information on what activities can or cannot occur on and around the mound, reserve area, and greenbelt area.
6. A standard homeowner "Do's and Don'ts" list for proper system operation.
7. Information regarding suitable landscaping and vegetation for the mound and surrounding areas.

APPENDIX A

Figure 1- Mound System Components

Figure 2 - Typical Site Plan

Figure 3 - Mound Dimension Reference and Cross Section

Figure 4 - Treatment Sand Specifications

Table 1 - Allowable Soil Loading Rates; Sites with ≥ 24 Inches of Sand Fill

Table 2 - Allowable Soil Loading Rates; Sites with < 24 Inches of Sand Fill

Table 3 - Slope Correction Factors

Figure 1
Typical Mound System Components

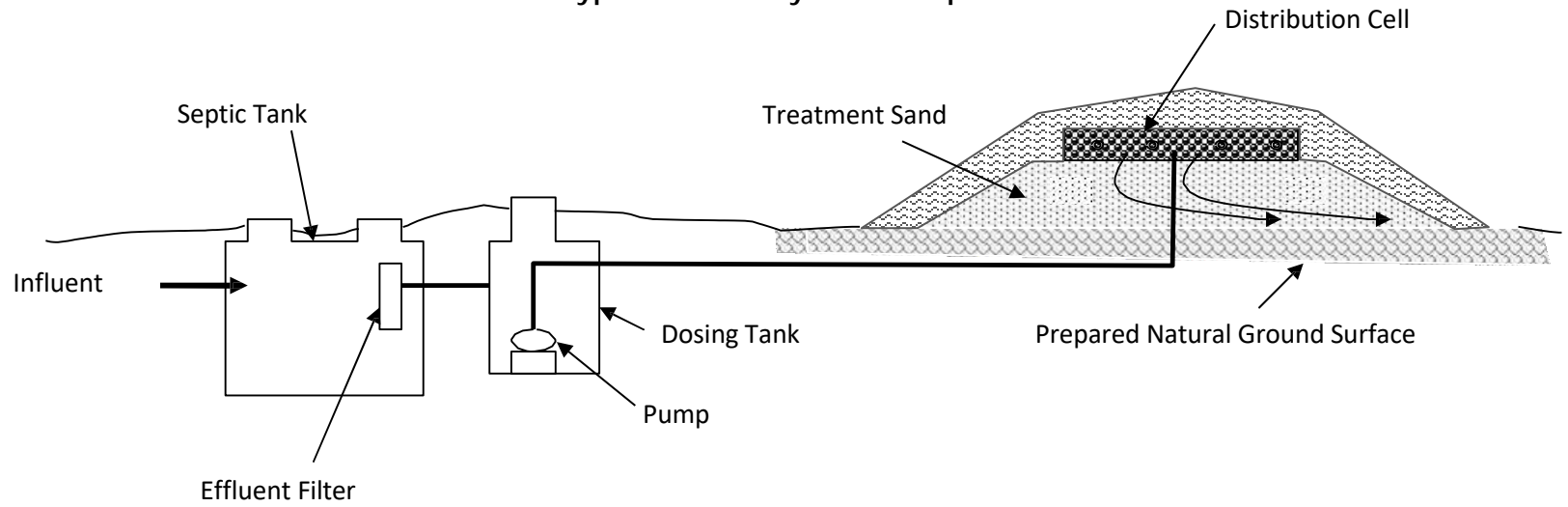

Figure 2
Typical Site Plan

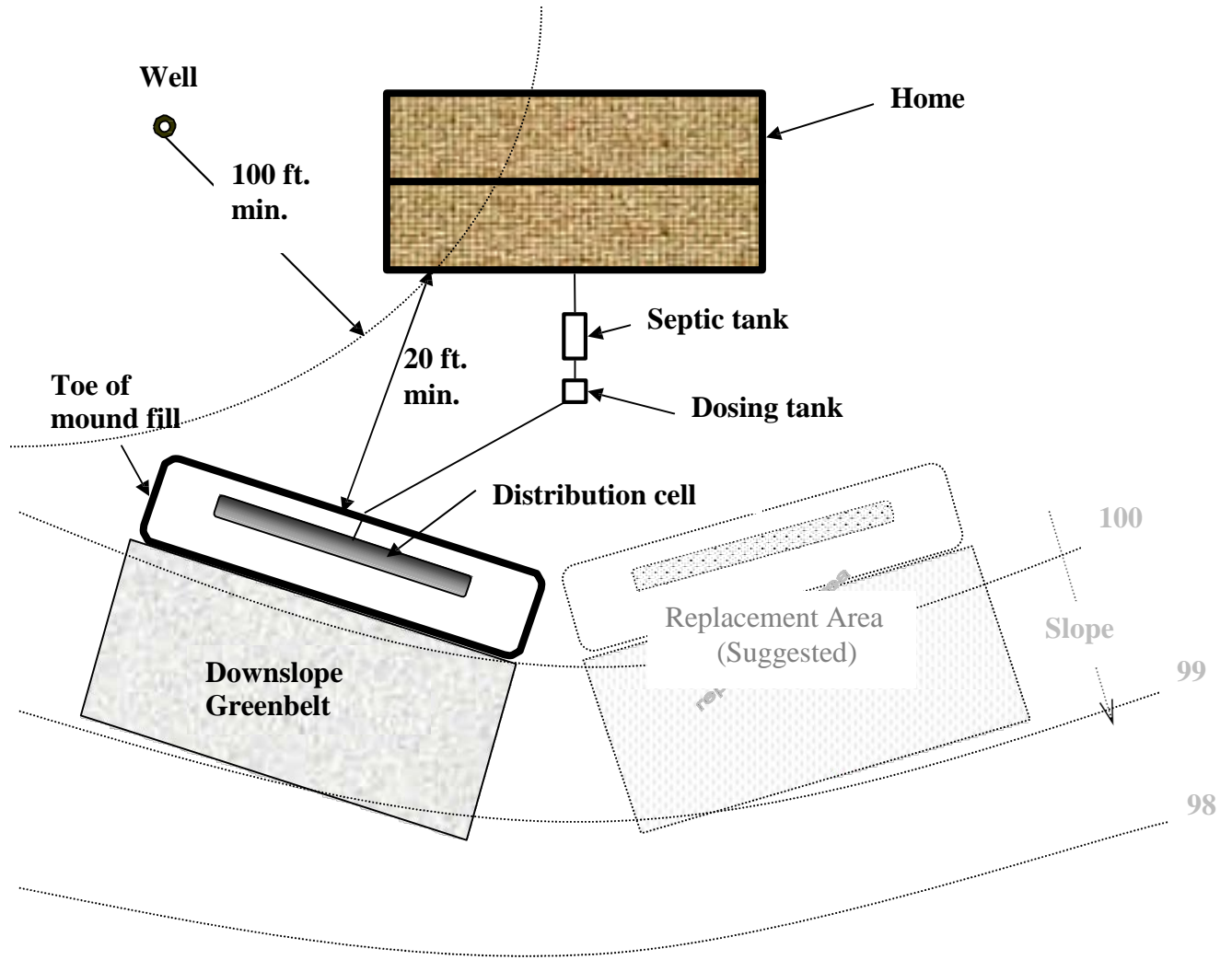
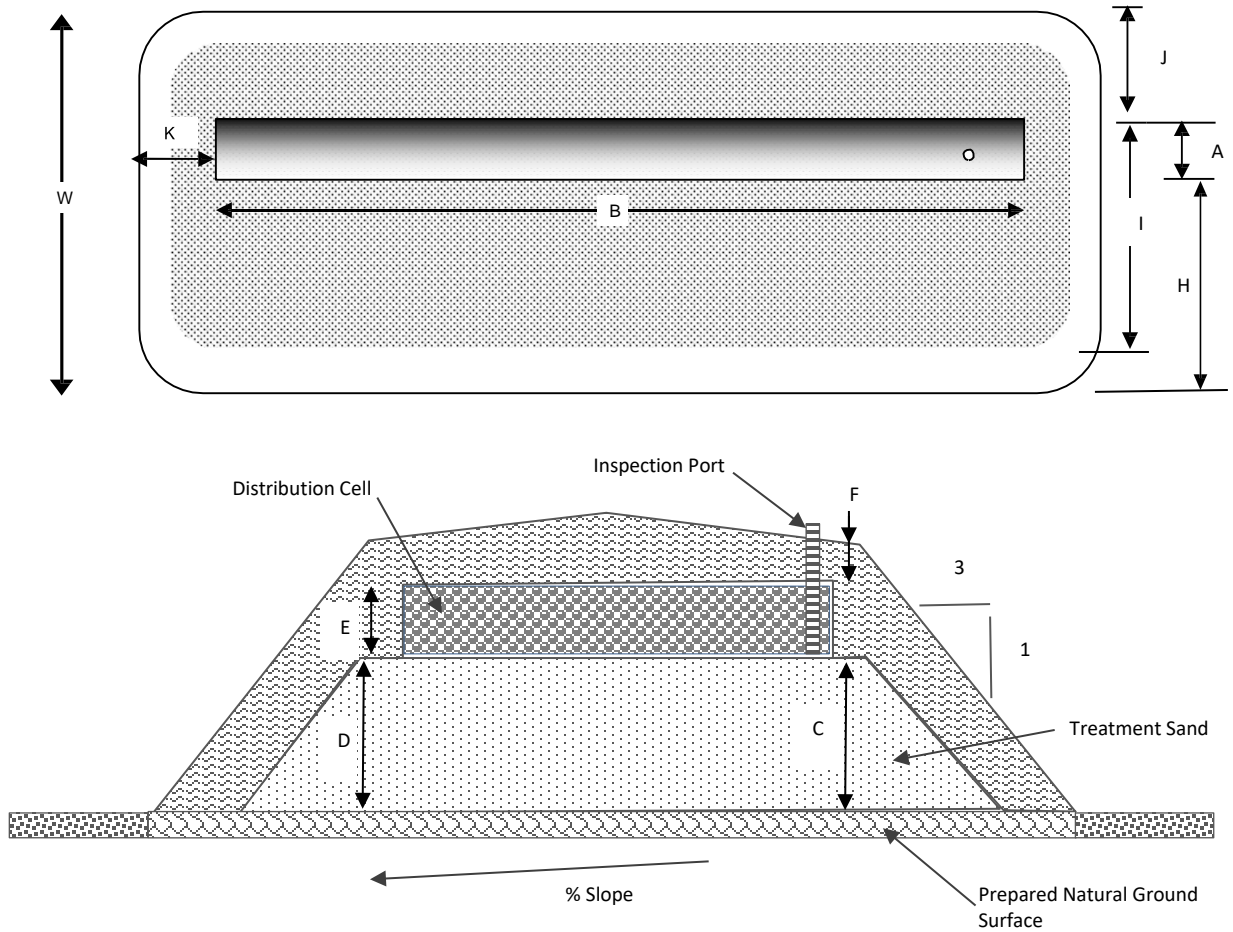

Figure 3

Mound Dimension and Cross-Section



Legend

- A - Distribution cell width
- B - Distribution cell length
- C - Up slope fill depth under distribution cell
- D - Downslope fill depth under distribution cell
- E - Distribution cell depth
- F - Depth of final cover
- H - Distance from edge of distribution cell to downslope toe of fill
- I - Downslope area required for effluent to infiltrate into the existing soil
- J - Distance from edge of distribution cell to up-slope edge of fill
- K - Distance from end of distribution cell to edge of fill (side-slope)
- L - Overall mound fill length
- W - Overall mound fill width

Figure 4

Treatment Sand Specifications

"Preferred" sand media requirements:

Effective size: 0.25-0.60 mm

Uniformity coefficient: ≤ 4.0

Percent fines passing #200 sieve: ≤ 3.0

Allowable preferred sand application rate: 1.0 gpd/ft.²

"Secondary" sand media requirements:

Effective size: 0.15-0.60 mm

Uniformity coefficient: ≤ 7.0

Percent fines passing #200 sieve: ≤ 3.0

Allowable secondary sand application rate: 0.8 gpd/ft.²

Per section 43.11.C.2.d.4 of Regulation 43, a gradation of the sand media used must be provided. The gradation must be dated no more than one month prior to the system installation date.

Table 1

**Allowable Loading Rates for Sites
With Greater Than 24 Inches of Treatment Sand Imported**

<i>SOIL TYPE FROM TABLE 10-1</i>	<i>MAX. SOIL⁽¹⁾ LOADING RATE, GPD/SQ.FT. (TL3; Table 10-1)</i>	<i>MAX.⁽²⁾ LINEAR LOADING RATE, GPD/LF</i>	<i>RECOMENDED DOWNSLOPE GREENBELT (Feet)</i>
R ⁽³⁾	See Table 10-1A	3.0 - 12.0 ⁽⁴⁾	X ⁽⁴⁾
1	1.55	6.0 - 12.0	10
2	1.10	6.0 - 12.0	10
2A	0.90	6.0 - 12.0	20
3	0.65	6.0 - 12.0	30
3A	0.55	3.0 - 5.0	40
4	0.30	3.0 - 5.0	50
4A	0.20	3.0 - 5.0	50
5	0.15	3.0 - 5.0	75

(1) THE MAXIMUM SOIL LOADING RATE MUST BE DETERMINED RELATIVE TO THE SOIL HORIZON (in-situ soil) THAT IS IN CONTACT WITH THE IMPORTED TREATMENT SAND. LOADING RATES CORRESPOND TO SOIL TYPES FROM TABLE 10-1, or 10-1A (REGULATION 43) AS APPROPRIATE.

(2) THE MAXIMUM LINEAR LOADING RATE FOR SITES WHERE A "SECONDARY SAND MEDIA" WILL BE USED IS 9.5 GPD/LF. THIS IS NECESSARY TO ADDRESSES THE MAXIMUM CELL WIDTH REQUIREMENT OF 12 FEET.

(3) THIS INCLUDES SOIL TYPES R-0, R-1, AND R-2

(4) THE LINEAR LOADING RATE AND RECOMMENDED GREENBELT WILL BE DETERMINED FROM THE TYPE OF SOIL MATRIX THAT IS INTEGRAL TO THE RECEIVING SOIL BELOW THE SAND; EXCLUDING THE ROCK COMPONENT. REFER TO THE LINEAR LOADING RATE AND GREENBELT RANGES PROVIDED IN THIS CHART FOR THE APPROPRIATE SOIL TYPES. BOTH THE RECEIVING SOIL AND SLOPE OF THE SITE NEED TO BE CONSIDERED.

Table 2

**Allowable Loading Rates for Sites
With Less Than 24 Inches of Treatment Sand Imported**

<i>SOIL TYPE FROM TABLE 10-1</i>	<i>MAX. SOIL⁽¹⁾ LOADING RATE, GPD/SQ.FT. (TL1; Table 10-1)</i>	<i>MAX.⁽²⁾ LINEAR LOADING RATE, GPD/LF</i>	<i>RECOMENDED DOWNSLOPE GREENBELT (Feet)</i>
1	0.8	6.0 - 12.0	10
2	0.60	6.0 - 12.0	10
2A	0.50	6.0 - 12.0	20
3	0.35	6.0 - 12.0	30
3A	0.30	3.0 - 5.0	40
4	0.20	3.0 - 5.0	50
4A	0.15	3.0 - 5.0	50
5	0.10	3.0 - 5.0	75

(1) THE MAXIMUM SOIL LOADING RATE MUST BE DETERMINED RELATIVE TO THE MOST LIMITING SOIL LAYER WITHIN 36 INCHES BELOW THE TOP OF THE IMPORTED TREATMENT SAND. LOADING RATES CORRESPOND TO SOIL TYPES FROM TABLE 10-1 (REGULATION 43).

(2) THE MAXIMUM LINEAR LOADING RATE FOR SITES WHERE A "SECONDARY SAND MEDIA" WILL BE USED IS 9.5 GPD/LF. THIS IS NECESSARY TO ADDRESS THE MAXIMUM CELL WIDTH REQUIREMENT OF 12 FEET.

3) SIZE ADJUSTMENT FACTORS PROVIDED IN TABLE 10-3 MAY BE USED.

Table 3

Down Slope and Up Slope Correction Factors

Slope %	Down Slope Correction Factor	Up Slope Correction Factor
0	1.00	1.00
1	1.03	0.97
2	1.06	0.94
3	1.10	0.92
4	1.14	0.89
5	1.18	0.88
6	1.22	0.85
7	1.27	0.83
8	1.32	0.80
9	1.38	0.79
10	1.44	0.77
11	1.51	0.75
12	1.57	0.73
13	1.64	0.72
14	1.72	0.71
15	1.82	0.69
16	1.92	0.68
17	2.04	0.66
18	2.17	0.65
19	2.33	0.64
20	2.50	0.62
21	2.70	0.61
22	2.94	0.60
23	3.23	0.59
24	3.57	0.58
25	4.00	0.57

- CORRECTION FACTORS TO BE USED IN STEPS 10 AND 11 OF DESIGN EXAMPLES

APPENDIX B-1; Design example

Note: This design example will apply to all systems where the infiltrative surface is at or above existing grade, and where a minimum of 24" of treatment sand has been imported.

The design of a mound system requires that you define the following:

- 1) quality and quantity of wastewater,
- 2) sand media loading rate,
- 3) soil (basal) loading rate, and
- 4) linear loading rate.

Once these are established, the design can be completed. Note that pressure distribution is required as an integral component on all mound systems.

Site Criteria

1. Soil Profile:
 - A. 0-6 in. - Dark grayish brown loam, weak granular structure. (Soil type 2A)
 - B. 6-32 in. - Brown Sandy Clay, moderate blocky structure; distinct gray iron oxide masses and depletions noted at 12" below grade. (Soil type 4)
 - C. 32-48 in. - Moist Reddish brown Sandy Clay Loam, strong blocky structure, distinct gray iron oxide depletions throughout. (Soil type3)
 - D. 48-72 in. - Brown Sandy Clay, massive structure; iron masses and depletions throughout. (Soil type 4A)
2. Site Slope: 10%
3. This design is for a proposed 3 bedroom home; thus 450 gpd.

Design overview: A limiting layer (Redoximorphic features - "distinct gray iron oxide masses and depletions") was noted at 12 inches below grade. The vertical separation requirement above a limiting layer when TL1 or TL2 effluent is applied to the distribution media is 36 inches (Section 43.11.C.3.c, Regulation 43). Therefore, the minimum elevation for the infiltrative surface is 24 inches above grade. As the mound will have a minimum of 24" of treatment sand imported, TL3 LTAR may be used as the soil loading rate to the in-situ soil. This example assumes that no additional treatment of the effluent was provided prior to being dosed to the mound system.

Step 1. Evaluate the quantity and quality of wastewater generated.

The system will be designed to receive domestic strength wastewater from three bedroom home. Design flows are established based on section 43.6 of Regulation 43 and the additional decisions by the local public health agency. For this design example, an estimate of 150 gallons per day (gpd) per bedroom x 3 bedrooms equates to a design flow rate of 450 gpd.

Step 2. Evaluate the soil profile and site description to determine the appropriate soil (basal) loading rate and the hydraulic linear loading rate.

From the soil profile description, the most limiting soil horizon is the soil type 4 with redoximorphic features at 12 inches below grade. Using the information provided in Table 1, the soil loading rate and linear loading rate is selected.

$$\text{Soil (Basal) Loading Rate (SLR)} = 0.3 \text{ gpd/ft}^2$$

$$\text{Linear Loading Rate (LLR)} = 5.0 \text{ gpd/lineal foot}$$

Step 3. Select the sand fill loading rate.

The sand media selected for this design is a "secondary sand media", thus from Figure 4 the allowable loading rate is 0.8 gpd/ft². Adjustment factors defined in Table 10-3 are not allowed in mound systems where TL3 application rates are used subsequent to placement of a minimum of 24" of sand media.

$$\text{Sand Fill Loading Rate} = 0.8 \text{ gpd/ft}^2$$

Step 4. Determine the distribution cell width (A).

The width of the absorption area is a function of the hydraulic linear loading rate (based on the most limiting soil horizon) and the sand fill loading rate.

$$\begin{aligned} A &= \text{Linear Loading Rate} \div \text{Sand Fill Loading Rate} \\ &= 5.0 \text{ gpd/ft.} \div 0.8 \text{ gpd/ft}^2 \\ &= 6.25 \text{ ft. width of cell} \end{aligned}$$

Step 5. Determine the distribution cell length (B).

$$\begin{aligned} B &= \text{Design Flow Rate} \div \text{Linear Loading Rate} \\ &= 450 \text{ gpd} \div 5.0 \text{ gpd/ft} \\ &= 90 \text{ ft. length of cell} \end{aligned}$$

Note: Regulation 43 requires a one foot extension of the minimum final cover elevation around the entire perimeter of the mound prior to the allowable 3:1 slope down to existing grade. Thus, the designer must be aware that the final

cover dimension above the gravel will be 8.25 feet x 92 feet. This additional foot will be addressed in Steps 8 and 13.

Step 6. Determine the minimum basal area width (I); Note that this width also includes (A). This is the calculated total width required for the effluent to enter the in-situ soil. Thus, the minimum downslope area that must be covered by the imported treatment sand.

Even though the one foot extensions are added to the mound width and length as stated in the note in Step 5, it does not require a modification of the following formula. Therefore:

$$\begin{aligned} I &= \text{Linear Loading Rate} \div \text{Soil (Basal) Loading Rate} \\ &= 5.0 \text{ gpd/ft} \div 0.3 \text{ gpd/ft}^2 \\ &= 16.67 \text{ ft.} \end{aligned}$$

As the width of the distribution cell is 6.25', the required additional sand fill downslope of the distribution cell is 10.42';

- $16.67 - 6.25 = 10.42'$

(Note: The total downslope area required to be filled will also be calculated based on side slope, which may or may not result in a greater width requirement; This width will be defined as (H), calculated in Step 10)

Step 7. Determine mound fill depth (C) at the upslope edge of the distribution cell.

From the information provided in the "Site Criteria" and "Design Overview" sections, the depth of fill (C) at the upslope edge of the distribution cell will be the fill required to elevate the base of the stone 36 inches above the limiting layer; which was noted at 12 inches below grade. Thus, 36 inches - 12 inches = 24 inches of sand required. This assumes that the base of the sand will be installed at existing grade. Further note that the in-situ soil, at grade, will need to be properly scarified; as described on pg. 10 of this document.

$$(C) = 24 \text{ inches (or 2.0 feet)}$$

Step 8. Determine the mound fill depth (D) at the downslope edge of the distribution cell.

The slope of the site was determined to be 10%. The following formula is provided:

$$\begin{aligned} D &= C + [\text{site slope} \times (A + 1)] \\ \text{Note: The "+1" is added to address the 1' mound extension noted in Step 5.} \\ &= 2.0 + [0.10(6.25 + 1)] \\ &= 2.73 \text{ ft.} \end{aligned}$$

Step 9. Determine mound depths (E) and (F).

$$E = 10 \text{ inches (total depth of stone)}$$

F = 10 inches (minimum amount of final cover)

Step 10. Determine the downslope width (H).

Using a proposed grade slope of 3:1 the calculations is as follows:

$$\begin{aligned} H &= 3(D + E + F) \times \text{downslope correction factor (from Table 3)} \\ &= 3(2.73 + 0.83 + 0.83)(1.44) \\ &= 18.96 \text{ ft.} \end{aligned}$$

As the 18.96 ft. is greater than the 16.67 ft. ("I" in step 6) the 18.96 ft. width will be used for "H".

(Note: In some designs the "H" may or may not require additional fill to be placed further downslope than what "I" requires. If "I" in Step 6 is larger than "H" in Step 10, the sand media must extend to "I", with cover material on top)

Step 11. Determine the upslope width (J).

Using a side slope of 3:1, the calculation is as follows:

$$\begin{aligned} J &= 3(C + E + F) \times \text{upslope correction factor; from Table 3} \\ &= 3(2.0 + 0.83 + 0.83)(0.77) \\ &= 8.45 \text{ ft.} \end{aligned}$$

Step 12. Determine the end slope length (K).

Using a side slope of 3:1, the calculation is as follows:

$$\begin{aligned} K &= 3[(C+D)/2 + E + F] \\ &= 3[(2.0 + 2.73)/2 + 0.83 + 0.83] \\ &= 12.08 \text{ ft.} \end{aligned}$$

Step 13. Determine the overall width (W) and length (L) of the mound fill.

Note: The additional 1' mound extension around the mound perimeter noted in Step 5 will be added to the "A" and "B" calculations in this step; Noted below as (A + 2) and (B + 2).

$$\begin{aligned} W &= (A + 2) + H + J \\ &= 8.25 + 18.96 + 8.45 = 35.66 \text{ ft.} \end{aligned}$$

$$\begin{aligned} L &= (B + 2) + 2K \\ &= 92 + 2(12.08) \\ &= 116.16 \text{ ft.} \end{aligned}$$

A lettered cross-reference is summarized on the following plan view and cross section:

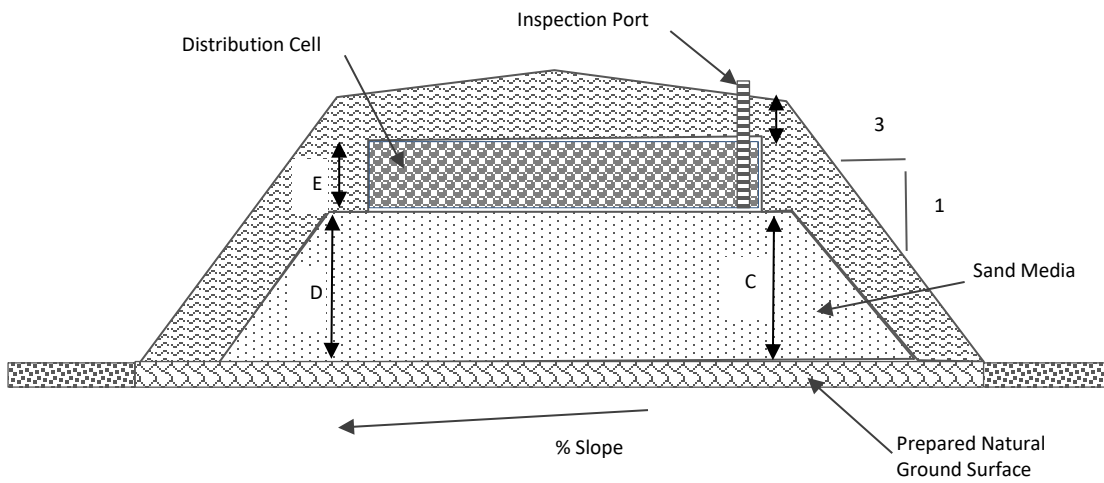
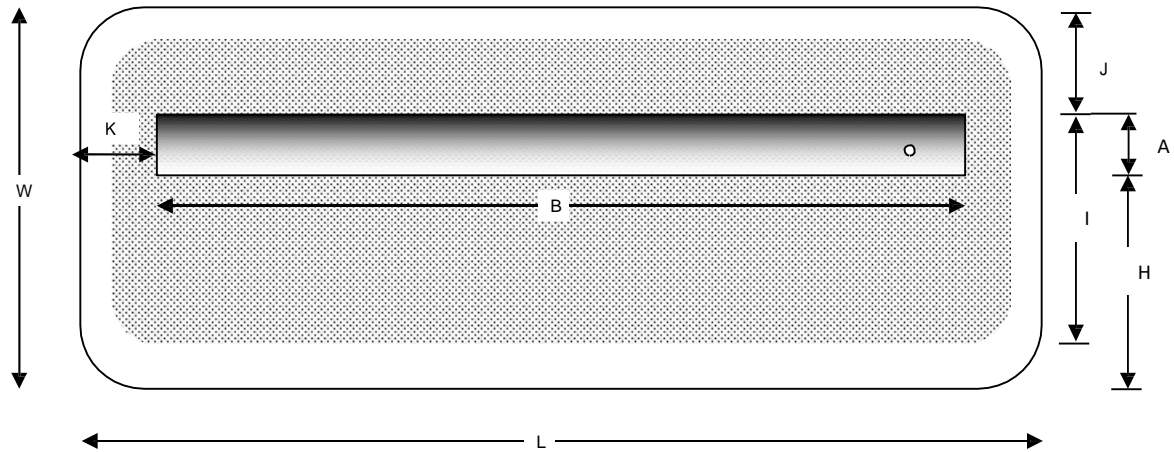

APPENDIX B-1; Calculated Dimensions

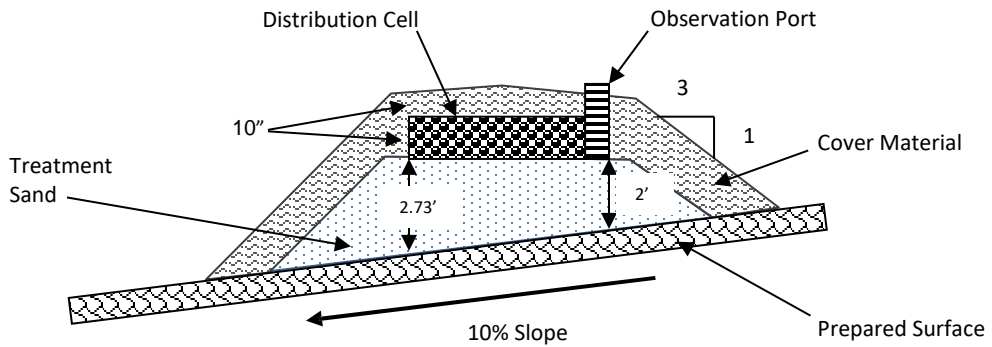
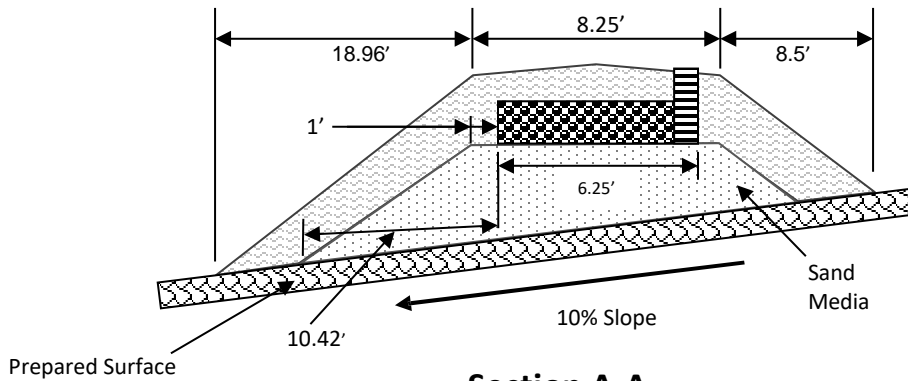
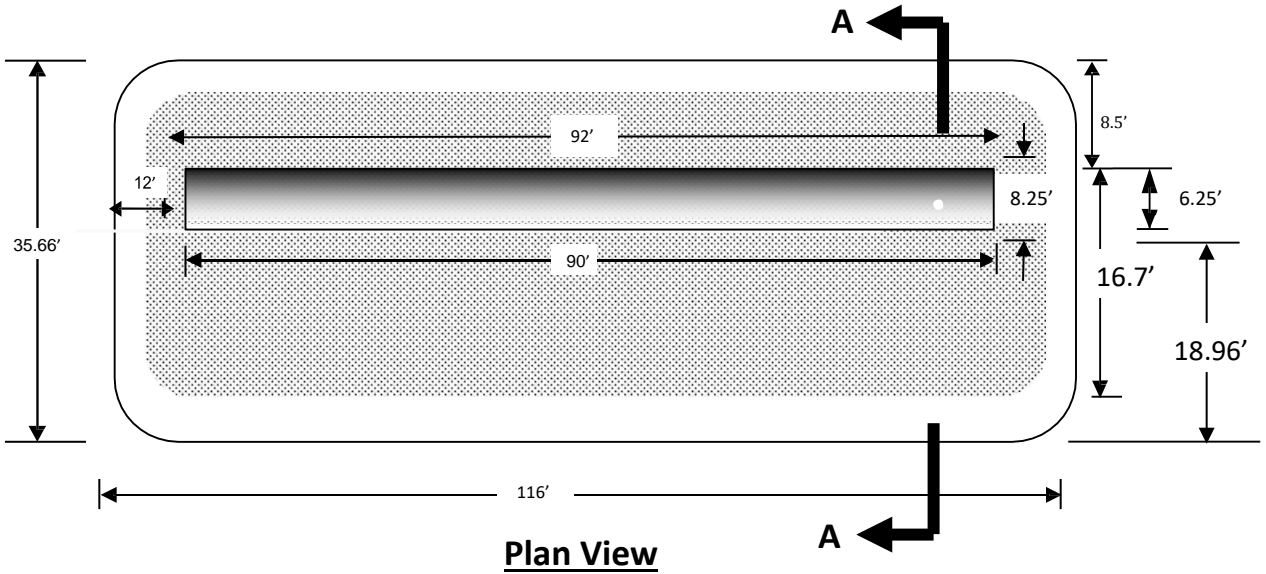

APPENDIX B-2; Design example

Design Example for a Site with Less Than 24" of Treatment Sand Imported

Note: This design example will apply to all systems where the infiltrative surface is at or above existing grade, and where < 24" of sand media is imported.

The design of a mound system requires that you define the following:

- 1) quality and quantity of wastewater,
- 2) sand media loading rate,
- 3) soil (basal) loading rate, and
- 4) linear loading rate.

Once these rates are established, the design can be completed. Note that pressure distribution is required in all mound systems.

Site Criteria

1. Soil Profile:
 - A. 0-6 in. - Dark grayish brown loamy sand, weak granular structure.
 - B. 6-48 in. - Reddish brown sandy loam, moderate blocky structure, distinct reddish iron oxide masses evident in soils below 28 inches. (Soil type 2)
 - C. 48-72 in. - Brown Clay Loam, moderate blocky structure, iron masses and depletions throughout. (Soil type 4)
2. Slope: 4%
3. This is a site for a proposed 3 bedroom home.

Design overview: A limiting layer (redoximorphic features) was noted at 28 inches below grade. With pressure distribution, the vertical separation requirement for the application of TL1 effluent is 36 inches above a limiting layer (Table 7-2, Regulation 43). Therefore the minimum elevation for the infiltrative surface is 8 inches above grade. Since the soil texture and structure is suitable within the treatment zone and only 8 inches of sand fill is proposed, the long term acceptance rates (TL1) of the in-situ soil from Table 10-1 in Regulation 43 must be used.

Step 1. Evaluate the quantity and quality of wastewater generated.

The system will be designed to receive domestic strength wastewater from three-bedroom home. Design flows are established based on section 43.6 of Regulation 43 and the additional decisions by the local public health agency. For this design example, an estimate of 150 gallons per day (gpd) per bedroom x 3 bedrooms equates to a design flow rate of 450 gpd.

As Regulation 43 allows for size adjustments defined in Table 10-3 for mound systems where <24" of imported treatment sand is used, the adjustment will be applied at this point in the design to allow for the balance of the mound system design process to progress per the defined standard. Chambers are proposed as the distribution system for this design and they are allowed a 0.7 adjustment factor (Table 10-3, Regulation 43), thus:

The calculated flow value for input in the upcoming calculations is: $450 \times 0.7 = 315$ gpd

Step 2. Evaluate the soil profile and site description for soil loading rate and hydraulic linear loading rate.

The most limiting soil horizon within 36 inches of the infiltrative surface, from a texture and structure standpoint, is the brown sandy loam with a moderate blocky structure (Soil type 2). As < 24 inches of sand fill is being proposed, the long term acceptance rate for this soil type (TL1) as defined in Table 10-1 of Regulation 43 must be used for the soil loading rate. Linear loading rates are defined in section 43.11.D.5 of Regulation 43. These rates are also provided in Table 2 of this document.

Soil Loading Rate (SLR) = 0.6 gpd/ft² (Soil Type 2)

Linear Loading Rate (LLR) = 9.0 gpd/ft (While LLRs up to 12.0 are allowed for this soil type, the LLR for this design has been reduced to 9.0 for the secondary sand media chosen for this site (see step 3 below), as a higher rate would have resulted in a bed width of greater than 12 feet; see Steps 3 and 4).

Step 3. Select the sand fill loading rate.

Assume that the only sand media available within close proximity to this site is "secondary sand media", thus from Figure 4 the sand fill loading rate is 0.8 gpd/ft². Use of this rate is based on the assumption that the sand fill under the distribution cell will meet the requirements defined in Figure 4.

Sand fill loading rate = 0.80 gpd/ft²

Step 4. Determine the distribution cell width (A).

The width of the absorption area is a function of the hydraulic linear loading rate (based on the most limiting horizon in the upper 36 inches) and the sand fill loading rate.

$$\begin{aligned} A &= \text{Linear Loading Rate} \div \text{Sand Fill Loading Rate} \\ &= 9.0 \text{ gpd/ft} \div 0.8 \text{ gpd/ft}^2 \\ &= 11.25 \text{ ft.} \end{aligned}$$

Note: The width of the distribution cell will be extended to 11.5' to accommodate four rows of chambers, (2.83' per chamber x 4 = **11.33'**).

Step 5. Determine the distribution cell length (B).

$$\begin{aligned} B &= \text{Design Flow} \div \text{Linear Loading Rate} \\ &= 315 \text{ gpd} \div 9.0 \text{ gpd/ft}^2 \\ &= 35 \text{ ft.} \end{aligned}$$

Note: The length of the distribution cell will be extended to 36' to accommodate nine chambers in each row, (9 x 4' per chamber = **36'**).

Note: Regulation 43 requires a one foot extension of the minimum final cover elevation around the entire perimeter of the mound prior to the allowable 3:1 slope to match existing grade. Thus, the designer must be aware that the final cover dimension above the gravel will be 13.5 feet x 38 feet. This additional foot will be addressed in Steps 8 and 13.

Step 6. Determine the minimum basal area width (I). Note that this width also includes (A). This is the calculated total width required for the effluent to enter the in-situ soil. Thus, the minimum downslope area that must be covered by the imported treatment sand.

Even though the one foot extensions are added to the mound width and length as stated in the note in Step 5, it does not require a modification of the following formula. Therefore:

$$\begin{aligned} I &= \text{Linear Loading Rate} \div \text{Soil (Basal) Loading Rate} \\ &= 9.0 \text{ gpd/ft} \div 0.6 \text{ gpd/ft}^2 \\ &= 15.0 \text{ ft.} \end{aligned}$$

As the width of the distribution cell is 11.33', the required sand fill downslope of the distribution cell is 3.67';

- $15.0 - 11.33 = 3.67'$

(Note: The total downslope area required to be filled will also be calculated based on side slope, which may, or may not result in a greater width requirement; This width is defined as (H), calculated in Step 10)

Step 7. Determine mound fill depth (C) at the upslope edge of the distribution cell.

In this case, the depth of fill (C) at the upslope edge of the distribution cell will be the fill required to elevate the base of the stone three feet above high groundwater elevation. Redoximorphic features were noted at 28", thus the minimum additional elevation required for this design is 8 inches, or 0.67 feet. Further note that the in-situ soil, at grade, will need to be properly scarified; as described on pg. 10 of this document.

Step 8. Determine the mound fill depth (D) at the downslope edge of the distribution cell.

The slope of the site was determined to be 4%. The following formula is provided:

$$D = C + 0.04(A + 1)$$

Note: The "+1" is added to address the 1' mound extension noted in Step 5.

$$= 0.67 + 0.04(11.5 + 1)$$

$$= 1.17 \text{ ft.}$$

Step 9. Determine mound depths (E) and (F).

E = 8 inches (a low profile chamber unit is proposed)

F = 10 inches (minimum amount of final cover)

Step 10. Determine the downslope width (H).

Using a recommended side slope of 3:1, the calculation is as follows:

$$H = 3(D + E + F) \times \text{downslope correction factor}$$

$$= 3(1.17 + 0.67 + 0.83)(1.14)$$

$$= 9.13 \text{ ft.}$$

As the 9.13 ft. is greater than the 3.67 ft. ("I" in step 6), the 9.13 ft. width will be used for "H".

(Note: In some designs the "H" may or may not require additional fill to be placed further downslope than what "I" requires. If "I" in Step 6 is larger than "H" in Step 10, the sand media must extend to "I", with cover material on top.)

Step 11. Determine the upslope width (J).

Using a recommended side slope of 3:1, the calculation is as follows:

$$J = 3(C + E + F) \times \text{upslope correction factor}$$

$$= 3(0.67 + 0.67 + 0.83)(0.89)$$

$$= 5.8 \text{ ft.}$$

Step 12. Determine the end slope length (K).

Using a recommended side slope of 3:1 the calculations is as follows:

$$\begin{aligned} K &= 3[(C + D)/2 + E + F] \\ &= 3[(0.67 + 1.17)/2 + 0.67 + 0.83] \\ &= 7.26 \text{ ft.} \end{aligned}$$

Step 13. Determine the overall width (W) and length (L) of the mound fill.

Note: The additional 1' mound extension around the mound perimeter noted in Step 5 will be added to the "A" and "B" calculations in this step.

$$\begin{aligned} W &= (A + 2) + H + J \\ &= 13.5 + 9.13 + 5.8 \\ &= 28.43 \text{ ft. (Use 28.5 ft.)} \end{aligned}$$

$$\begin{aligned} L &= (B + 2) + 2K \\ &= 38 + 2(7.26) \\ &= 50.52 \text{ ft. (Use 50.5 ft.)} \end{aligned}$$

APPENDIX B-2; Calculated Dimensions

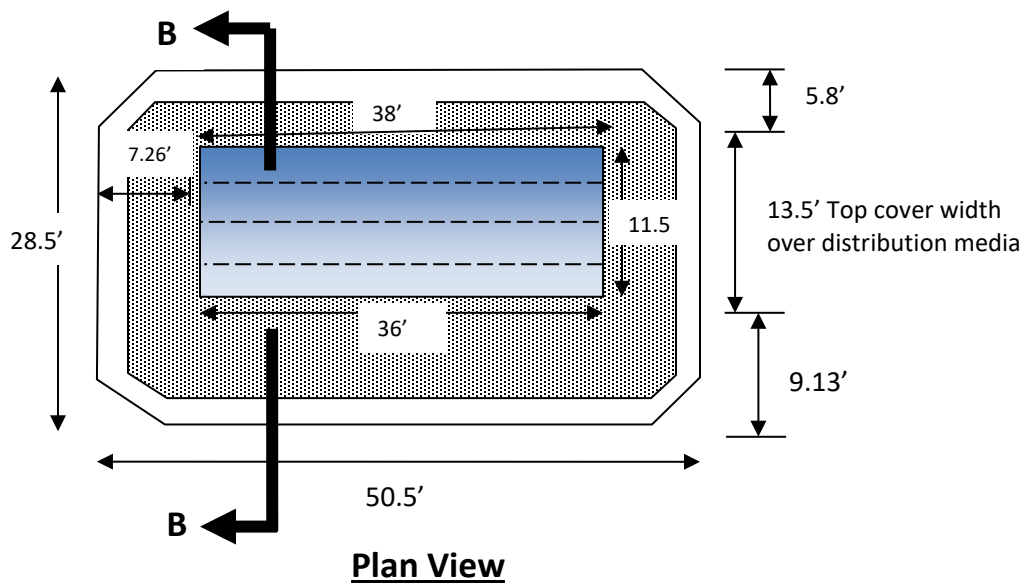

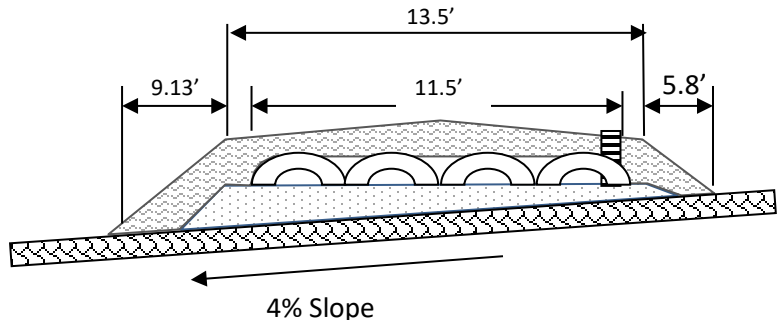

Section B-B

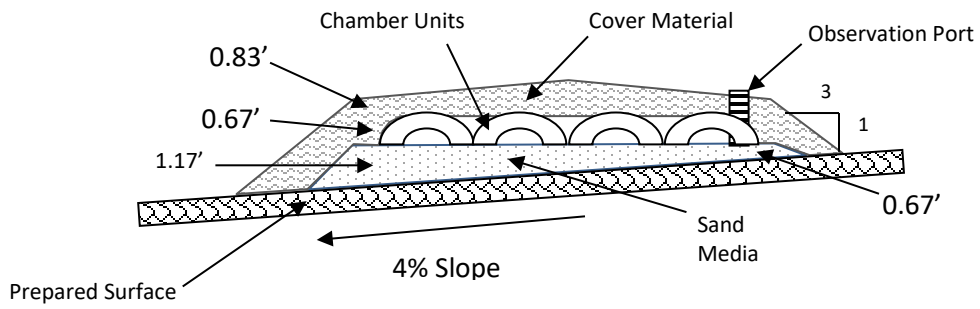

Section B-B

APPENDIX C

Mound Design Worksheet

Site Criteria

1. Soil Profile

2. Slope: _____%

3. This is a site for a proposed _____ bedroom home.

Step 1. Evaluate the quantity and quality of wastewater generated.

Residential flows: YES NO (If "No", Pretreatment and/or a design flow safety factor may be required)

Daily Flow = # of bedrooms x 150 gpd/bedroom for first 3 bedrooms; 75 gpd/bedroom for each additional bedroom. (Local requirements may also apply)

$$= (\text{_____} \times 150) \text{ gpd}$$
$$= \text{_____} \text{ gpd}$$

Step 2. Evaluate the soil profile and site description for maximum soil loading rate and hydraulic linear loading rate.

Depth to Limiting Layer = _____ inches

Define Limiting Layer; _____

Using Tables 2 & 3 the soil loading rate (SLR) and linear loading rate (LLR) are selected.

Soil Loading Rate (SLR) = _____ gpd/ft²

Linear Loading Rate (LLR) = _____ gpd/lineal foot

Step 3. Select the sand fill loading rate; (From Figure 4)

Will "Preferred Sand" or "Secondary Sand" be used for this design? Therefore, the sand fill loading rate will be either (circle one): 1.0 gpd/ft². 0.8 gpd/ft².

Step 4. Determine the distribution cell width (A).

$$\begin{aligned} A &= \text{Linear Loading Rate} \div \text{Sand Fill Loading Rate} \\ &= \underline{\hspace{2cm}} \text{ gpd/ft.} \div \underline{\hspace{2cm}} \text{ gpd/ft}^2 \\ &= \underline{\hspace{2cm}} \text{ ft.} \end{aligned}$$

Step 5. Determine the distribution cell length (B).

$$\begin{aligned} B &= \text{Design Flow} \div \text{Linear Loading Rate} \\ &= \underline{\hspace{2cm}} \text{ gpd} \div \underline{\hspace{2cm}} \text{ gpd/ft.} \\ &= \underline{\hspace{2cm}} \text{ ft.} \end{aligned}$$

Note: Per Regulation 43, a one foot extension of the minimum final cover elevation is required around the entire perimeter of the mound prior to the allowable 3:1 slope. Therefore, the final cover over the distribution cell width will be two feet larger than the numbers calculated in steps 4 and 5; One foot extension on each of the four sides.

Step 6. Determine the minimum basal area width (I); Note that this width also includes (A). This is the calculated total width required for the effluent to enter the in-situ soil. Thus, the minimum downslope area that must be covered by the imported treatment sand. Reference drawing, pg. 15

Even though the one foot extensions are added to the mound width and length as stated in the note in Step 5, it does not require a modification of the following formula. Therefore:

The soil infiltration width represents the width required (below, and downgradient of the distribution cell) to absorb the effluent into the natural soil.

$$\begin{aligned} I &= \text{Linear Loading Rate} \div \text{Soil (Basal) Loading Rate} \\ &= \underline{\hspace{2cm}} \text{ gpd/ft}^2 \div \underline{\hspace{2cm}} \text{ gpd/ft}^2 \\ &= \underline{\hspace{2cm}} \text{ ft.} \end{aligned}$$

As the width of the distribution cell is (A)_____, the required sand fill downslope of the distribution cell is _____;

- (I) - (A) = Required sand fill area downslope of distribution cell

(Note: The total downslope area required to be filled will also be calculated based on side slope, which may or may not result in a greater width requirement; This width will be defined as (H), calculated in Step 10)

Step 7. Determine mound fill depth (C) at the upslope edge of the distribution cell.

The depth of fill (C) at the upslope edge of the distribution cell will be the fill required to elevate the base of the stone the required height above the limiting layer.

The required elevation above grade is _____ feet.

Step 8. Determine the mound fill depth (D) at the downslope edge of the distribution cell.

For a given slope, the following can be used:

$$\begin{aligned} D &= C + [\text{site slope} \times (A + 1)] \text{ Note: express slope as decimal, i.e., } 4\% = 0.04 \\ &= \underline{\hspace{2cm}} + [\underline{\hspace{2cm}}(\underline{\hspace{2cm}} + \underline{\hspace{2cm}})] \\ &= \underline{\hspace{2cm}} \text{ ft.} \end{aligned}$$

Step 9. Determine mound depths (E) and (F).

E = _____ ft. (total depth of distribution media)

F = _____ ft. (minimum amount of final cover, 1 foot beyond cell)

Step 10. Determine the downslope width (H).

Using a recommended side slope of 3:1 the calculations is as follows:

$$\begin{aligned} H &= 3(D + E + F) \times \text{downslope correction factor} \\ &= 3(\underline{\hspace{2cm}} + \underline{\hspace{2cm}} + \underline{\hspace{2cm}})(\underline{\hspace{2cm}}) \\ &= \underline{\hspace{2cm}} \text{ ft.} \end{aligned}$$

(Note: In some designs the "H" may or may not require additional fill to be placed further downslope than what "I" requires (see Step 6); strictly due to slope. If "I" in Step 6 is larger than "H" in Step 10, the sand media must extend to "I", with cover material on top)

Step 11. Determine the upslope width (J).

Using a recommended side slope of 3:1 the calculations is as follows:

$$\begin{aligned} J &= 3(C + E + F) \times \text{upslope correction factor} \\ &= 3(\underline{\hspace{2cm}} + \underline{\hspace{2cm}} + \underline{\hspace{2cm}})(\underline{\hspace{2cm}}) \\ &= \underline{\hspace{2cm}} \text{ ft.} \end{aligned}$$

Step 12. Determine the end slope length (K).

Using a recommended side slope of 3:1 the calculations is as follows:

$$\begin{aligned} K &= 3[(C+D)/2 + E + F] \\ &= 3\left[\frac{\quad + \quad}{2} + \quad + \quad\right] \\ &= \quad \text{ft.} \end{aligned}$$

Step 13. Determine the overall width (W) and length (L) of the mound fill.

Note: The additional 1' mound extension around the mound perimeter noted in Step 5 will be added to the "A" and "B" calculations in this step; Noted below as (A + 2) and (B + 2).

$$\begin{aligned} W &= (A + 2) + I + J \\ &= \quad + \quad + \quad \\ &= \quad \text{ft.} \end{aligned}$$

$$\begin{aligned} L &= (B + 2) + 2K \\ &= \quad + 2(\quad) \\ &= \quad \text{ft.} \end{aligned}$$

The calculated dimensions may be summarized on the following plan view and cross section:

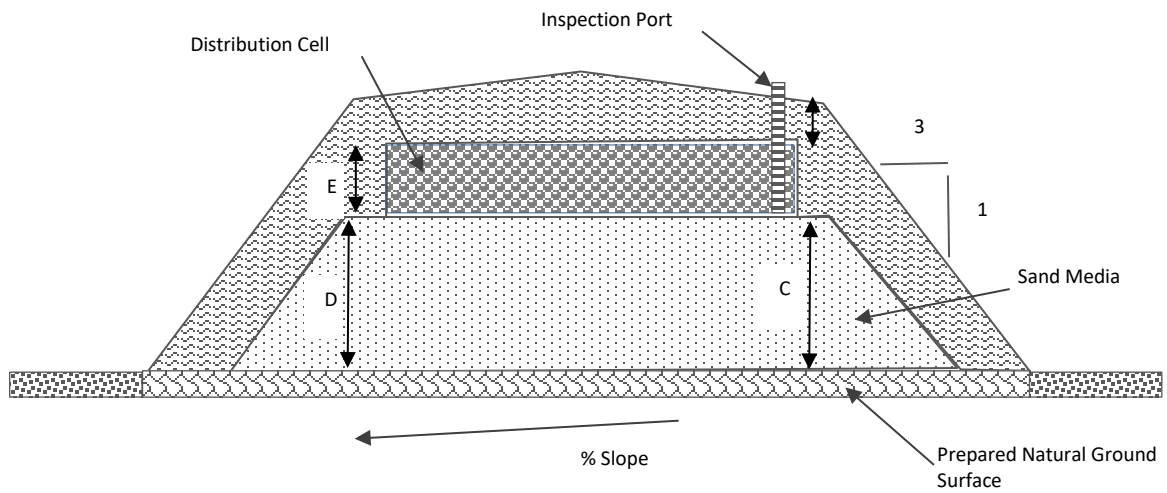
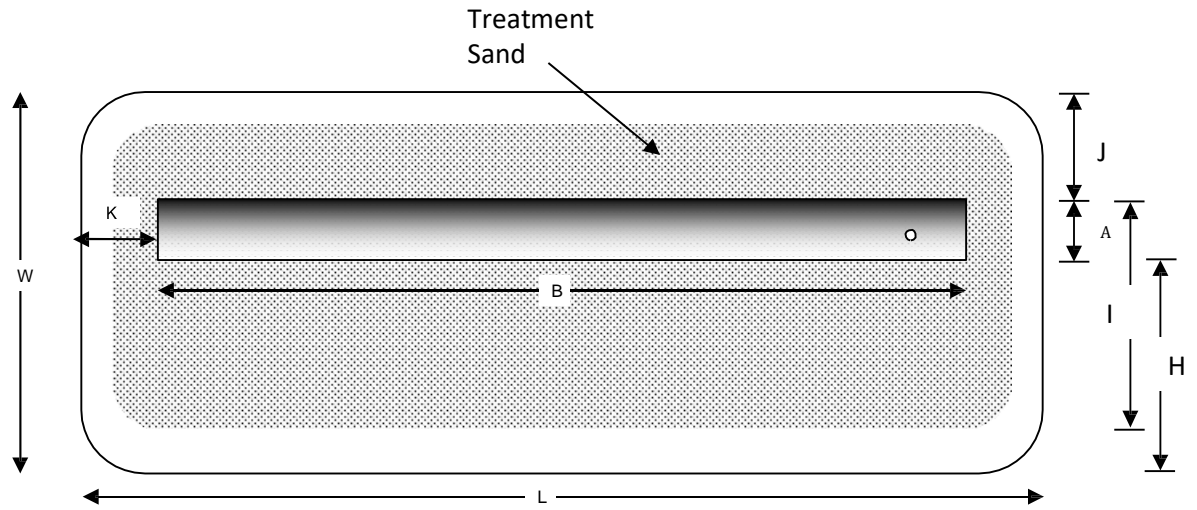

Mound Component Dimensions

Insert your
calculations below

A	Distribution cell width	
B	Distribution cell length	
C	Up slope fill depth under distribution cell	
D	Downslope fill depth under distribution cell	
E	Distribution cell depth	
F	Depth of final cover	
H	Distance from downslope edge of distribution cell to downslope toe of fill	
I	Calculated distance required for effluent to infiltrate into the existing soil; Treatment Sand fill area	
J	Distance from edge of distribution cell to up slope edge of fill	
K	Distance from end of distribution cell to edge of fill	
L	Overall mound fill length	
W	Overall mound fill width	
X	Proposed Side-Slope	

APPENDIX D

Suggested Plan Submittal Checklist:

In order to install a system correctly, it is important to develop overall plans that will clearly communicate how to install the system correctly. The following checklist may be used when preparing plans for review. The checklist is suggested as a general guide. Additional information may be necessary or requested to address unusual or unique characteristics of a particular project.

Forms and Fees

- Application form for submittal, provided by reviewing agency along with proper fees.

Report and Site Plan per Section 43.5.F of Regulation 43 (May be part of Design Document)

- Written Report describing preliminary investigation, reconnaissance
- Name, Address, Contact Information, etc. for individual conducting site evaluation
- Complete soil description for each soil test pit conducted.
- Scaled plot plan indicating test pit location, property lines, other required items.
- Benchmark, contours or slope.
- Proposed elevation of infiltrative surface.
- Additional items:

Design Document per Section 43.5.G of Regulation 43

- Brief description of proposed use, basis of design, proposed flows, waste strength
- Design document containing all necessary details for permitting and installation
- Scaled drawing with location of each OWTS component, property lines, applicable items
- Indicate setbacks from OWTS components to other features including wells, surface water
- Location and elevation of site benchmark
- Calculations for each component (as applicable). TDH and GPM for all dosing systems
- Detailed layout of soil treatment area and other system components
- Slope directions and percent slope in mound area (if contours are not provided)
- Component elevations including tank invert and infiltrative surface elevation

Additional items:

Additional Mound System Items

- Mound design calculations/worksheet
- Includes tilling requirement, distribution cell details, side slope, and cover material
- Sand fill specifications
- Sand Media gradation
- Proposed site grading plan

Tank and Pump Information

- All construction details for pumping system
- Notation of pump model, pump performance curve, calculations for TDH and GPM
- Cross section of dose tank/pump chamber, including storage volumes; float settings, dose volume, timer settings (as applicable), etc.

Documentation

- Plans signed sealed and dated by licensed professional.

Detailed Specifications

- Detailed specifications describing all phases of site preparation and construction including provisions for protection of mound areas prior to construction and testing.

Inspections

- Inspection must be made in accordance with requirements of the local public health agency. The inspection of the system installation and/or plans is to verify that the system at least conforms to specifications listed.
- Submittal from designer confirming that the installation complies with the approved plans and specifications.

APPENDIX E

Suggested Mound Maintenance Visit Checklist

 **General Observations**

Mound Appearance (check only items that may apply)

- Erosion has occurred
Explain _____
- Greener vegetation visible in spots
Explain _____

Toe of Slope Wetness

- Attractive, well groomed, completely vegetated
- Soil at downslope toe is soggy
- Water at surface of downslope toe
- Sewage odor around wet spots

General Condition

- Attractive, well groomed, completely vegetated
- Mostly vegetated, evidence of mowing
- Overgrown with weeds
- Overgrown with brush

 **Observation Tube(s) in Stone Bed**

- Observation tube(s) present
- Depth of ponding below grade (N,S,E,W, _____); (N,S,E,W, _____)
Circle tube location

 **Other Observation Tubes**

Describe and note distance to water below soil surface:

 **Pump Chamber**

Appearance: (Note any apparent problems or concerns)

- Water level normal; if no, describe _____

Pump operation is:

Demand (float) controlled

Timer controlled:

Number of floats: _____

Check float operation and desirable function of each (first visit only)

 **Control Panel**

If timer is present, note settings

_____ On time

_____ Off time

Event Counter Reading: _____

Pump Run Meter Reading: _____

 **Flush Laterals**

Access is provided to ends of lines

Have to dig up ends of lines (recommend addition of sumps for access)

Perform flush of each lateral, one lateral at a time. Record squirt height at end of each lateral using drilled end cap. Provide sketch to identify laterals.

Lateral #1 _____

Lateral #2 _____

Lateral #3 _____

Lateral #4 _____

Lateral #5 _____

Lateral #6 _____

After flushing all lines, obtain operating head measurement at the end of the line farthest from the pump. Note residual head and compare with previous records (if available). Does head vary from system start-up? _____. If head is more than 20 percent above previous value, bottle brush the lines - or otherwise clean - and measure head again.

Note final head: _____ft

APPENDIX F

Vertical Separation and Media Depth; Proposed Guidance for Regulation 43 Revision; June 30, 2017

The intent of this chart is to provide an overview of the vertical isolation requirements above a "Limiting Layer" as defined in Regulation 43. Note that other requirements such as long term acceptance rates and sand media requirements are addressed in other sections of Regulation 43

4' Separation Required

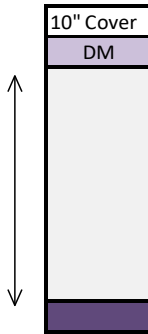

All systems in this category receive effluent via gravity flow

For all OWTS that receive TL1 effluent and utilize gravity flow in soil types 1-5, a 4' separation above a limiting layer is required

For the repair of an existing OWTS, or for the installation of a new OWTS, TL2-TL3N may be applied by gravity flow to the STA only in Soil Types 3A-5, (For designs requesting reductions in STA size or vertical/horizontal separation with the application of TL2 - TL3N effluent, pressure dosing is required as noted in the sections below)

This includes a STA utilizing rock and pipe or proprietary distribution products

2.5' - 3' Separation Required

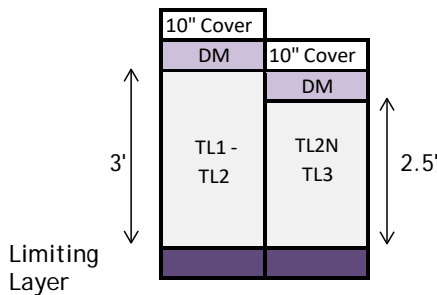

All systems in this category must receive effluent via pressure distribution

For an OWTS that receives TL1-TL2, a minimum 3' separation above a limiting layer is required. This also includes mound systems with <24" of sand

For all OWTS that receive TL2N-TL3, a minimum 2.5' separation above a limiting layer is required

For all mound systems that provide a minimum of 24" of sand, and receives TL1 - TL3 effluent, a minimum of 2.5' of separation above a limiting layer is required

Includes: Rip/Replace over a soil type "R"; an Unlined Sand Filter; a C.P.D./P.T.P.; or a standard installation using pressure distribution

2' Separation Required

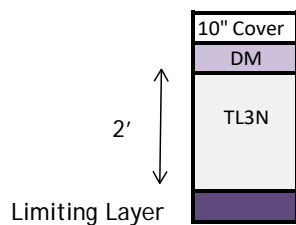

All systems in this category must receive effluent via pressure distribution

For all OWTS that receive TL3N, a minimum 2' separation above a limiting layer is required

Includes: Rip/Replace over a soil type "R"; an Unlined Sand Filter; a C.P.D./P.T.P.; or a standard installation using pressure distribution

LEGEND:

Distribution Media - Chambers - C.P.D./P.T.P.:



Limiting Layer:



C.P.D./P.T.P.: Combined Proprietary Distribution/Passive Treatment Products. The bottom of the C.P.D./P.T.P. is defined as the base of the sand that is required by the manufacturer to be placed below the product as per the literature provided to the Division

Limiting Layer: Means a horizon or condition in the soil profile or underlying strata that limits the treatment capability of the soil or severely restricts the movement of fluids. This may include soils with lower high permeability, impervious or fractured bedrock, or a seasonal or current ground water surface